

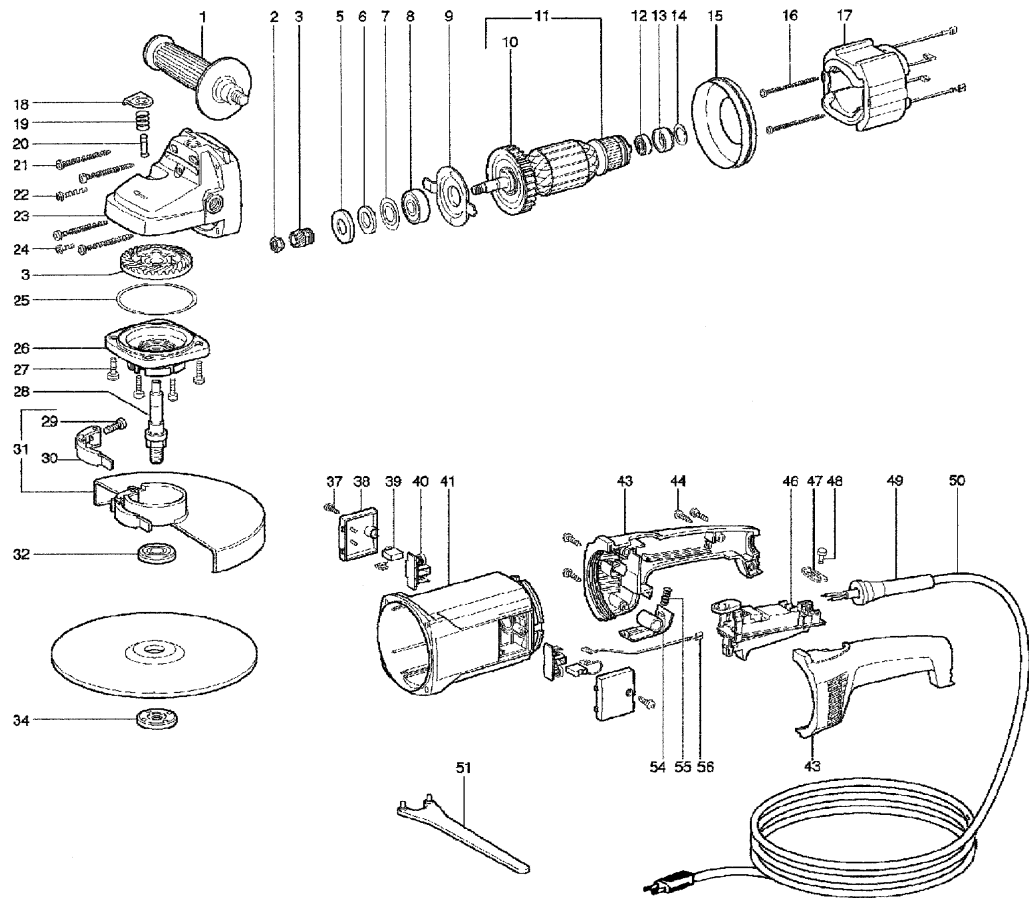

WALTER

MODEL 6170 D



No. Order No. Description

1	32-B 014	Side handle
2	48-K 416	Nut
3	48-M 259	Pinion/Crown wheel unit
5	48-K 191	Spacer ring
6	48-L 016	Felt ring
7	48-L 944	Cover plate
8	48-Q 023	Ball bearing
9	48-M 261	Cover plate
10	48-M 381	Fan
11	48-M 262	Armature
12	48-Q 002	Ball bearing
13	48-M 263	Bearing seat
14	48-K 156	Washer
15	48-M 267	Vent plate
16	48-S 183	Screw

No. Order No. Description

17	48-M 269	Field
18	48-M 276	Lock button
19	48-M 277	Spring
20	48-M 279	Pin
21	48-S 778	Screw
22	48-S 184	Screw
23	48-M 283	Gear housing
24	48-S 863	Screw
25	48-K 503	Spacer
26	48-M 284	Gear flange for 6170D
27	48-S 553	Screw
28	48-M 286	Spindle
29	48-S 185	Screw
30	48-M 287	Clamping lever
31	48-M 288	Guard for 6170 D
32	30-B 036	Flange

No. Order No. Description

34	30-B 037	Clamp nut
37	48-S 742	Screw
38	48-M 290	Cover
39	48-M 291	Carbon brush
40	48-M 292	Brush holder
41	48-M 293	Motor housing
43	48-M 295	Handle
44	48-S 714	Screw
46	48-M 317	Switch
47	48-M 318	Cable clamp
48	48-S 186	Screw
49	48-M 319	Cable sleeve
50	48-Z 210	Cord set
51	48-Z 148	Pin key
54	48-M 320	Handle lock
55	48-M 321	Spring
56	48-M 324	Lead